



We Provide All In One Solution

We keep pursuing excellence and provide the elevators with best quality to the world.



オールシリーズ
All Series



Index

PRODUCTS

New Cabin Dedsign	09	OBH	17
HAL Type	12	Passenger Lift	19
G9 Pitless Elevator	13	Cargo & Bed Lift	21
Machine Roomless	15	Escalator & Moving Walk	22

DESIGN

Ceiling	23	Operating Panel	25
Handrail	24	Landing	26

OTHERS

Features	27	Safety	29
Application	28	Function List	31

LAYOUTS



Passenger Lift	33	GPX	37
OBH	35	Bed Lift	38
Home Lift	36		





Japan Headquarter



	本社所在地 HEADQUARTER	〒270-0144 千葉県流山市前ヶ崎599-3 599-3, Maegasaki, Nagareyama Shi, Chiba Ken, 270-0144, Japan
	+81-3-45780389	

About JFI

JFIについて

JFIは自社の製品を日本から東南アジア、中東、中南米、アフリカなどに提供しています。

当社は日本に生産拠点を設けており、日本のJIS規格だけでなく、EUのCEマークなど多くの国や地域の各種認証を取得しています。

また高品質を維持するため、当社は日本AMADA製の機器を導入して製造を行っています。

国際マーケティング戦略を活かして、世界各地のエレベーターに関するご要望に応えています。

JFI is a renowned company providing its quality products from Japan to Singapore, Southeast Asia, the Middle East, North, Central, South America, and Africa.

JFI has its production base located in Japan. We've been recognized by legitimate authorities around the world and have passed various certifications, including European standard, CE, and relevant Japanese standards. To ensure the best quality, we also adopt Amada machine tools from Japan for manufacturing. Through international marketing strategies, we've successfully achieved the goal of having our elevators seen by people around the world.

Words from President Ota

社長メッセージ

当社は「日本品質を世界へ」を目標として、安全・安心なエレベーターを世界へ供給しています。私自身、日本で創業45年のエレベーター会社を営んでいます。その経験と製造メーカーおよびメンテナンス会社との協力体制をもって、世界の皆様へ日本品質のJFIエレベーターをお届けします。

With "Showing Japanese Quality to the World" as principle, we produce safe, reliable elevators for every country. I myself have been in this business for 45 years in Japan. By the experience and the cooperation of manufacturing and maintenance companies, we will continue providing Japan Fuji elevators with Japanese quality to the whole world.



President Hideki Ota



品質管理



各工程において厳格な基準で検査と記録を行っています。
例えば材料や半製品の検収、製造過程での検査、出荷前の完成品検査などがあります。

We conduct various inspections and record at each process based on rigorous criteria such as material/semi-finished product acceptance inspections, process inspections, and product inspections before shipments. In addition, we send the reports to our clients and verify the products with them.



会社登録 & 認定



Company
Registration



Europe ce Certificate



Machine
Roomless



Ucmp

設計と施工のフロー

ORDER PROCESS

Following is the standard of procedure for each order, start from the pricing quotation, client approval, manufacture and shipping.

お見積もり
Quotation

設計図
Drawings

Quotation (お見積もり)

- ◆ Major Specifications -基本仕様
- ◆ Production Specifications- 製品仕様
- ◆ Detailed Notes and Clarification - 詳細および明細

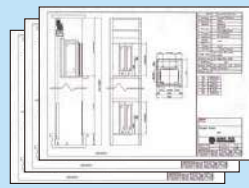

製品設計図

Approval (ご承認)

- ◆ Drawing - 設計図
- ◆ Proforma Invoice - インボイス
- ◆ Contract - ご契約



Approval
契約成立

規格と設計



精密な製造
Precision
Manufacturing

材料の製造
Ordering Material
Manufacturing



品質管理

Quality Control



パッキング
Packaging



輸送

Shipment



品質管理と工場管理



すべての材料、半製品、加工品、製品は、出荷前に必ず厳格な基準による製造過程での検査ならびに検査結果の記録を行っています。

We take a good care in every details

To Ensure our client recieved the best product in hand



すべての材料や半製品の検収、製造過程での検査、出荷前の完成品で検査と記録を行っています。検査結果はデータとして保管され、同時にお客様へご提示します。お客様と共同で製品を管理します。



梱包資材

最高の品質を提供するために、当社はきめ細かい管理を行っています。すべての材料や半製品、製品は必ずあらゆる工程で検査を実施しています。

All materials, semi-processed parts, processes, and products prior to shipment must be inspected and the results recorded during the manufacturing process in accordance with strict standards. In addition, the confirmed data are collated into a result report, which is presented to the customer and followed by a joint product inspection with the customer.



出荷管理



梱包材外観

高度な技術

JFIは日本に生産拠点を設けています。EUのCEマークや日本のJIS規格をはじめ、世界各地の認証機関より認証を受けています。また高品質を維持するため、当社は日本AMADA製の機器を導入して製造を行っています。国際マーケティング戦略を活かして、世界各地のエレベーターに関するご要望に応じています。

JFI has its production base located in Japan. We've been recognized by legitimate authorities around the world and have passed various certifications, including European standard, CE, and relevant Japanese standards. To ensure the best quality, we also adopt Amada machine tools from Japan for manufacturing. Through international marketing strategies, we've successfully achieved the goal of having our elevators

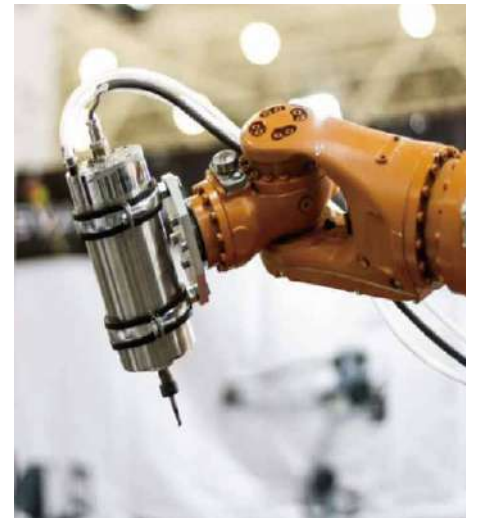

科学技術の日進月歩にJFIも歩みを止めず、一貫として最高の技術を取り入れています。JFIの研究開発チームは20年以上の経験を要しつつ、常に前進し続けています。AIエレベーター、クリーンエレベーター、多機能安全エレベーターなど地道な努力を重ねてきました。これらの高技術を要するエレベーターの製造のため、最高の製造設備やAMADA製の機器を設置しています。

Technologies is updating day by day, JFI has never stopped the steps. We are always leading ahead with the best technologies. JFI R&D team has experience over 20 years and keep going on. A.I. elevators, Epidemic Prevention elevators, Multi-safety functioned elevators are all showing our efforts. To produce these kinds of hi-tech elevators, we have the best production facilities with Amada machines and reliable production process.



JAPAN TECHNOLOGY PRECISION

レーザー加工機
Laser Processing Machine





グローバルな輸出

世界基準を満たすため、JFIは完結したプロセスでパッキングを行い、確実に当社製品と材料を受け取ることができます。製品が幅広い輸送方式に耐えられるよう安全に保護され、かつ容易に識別することができ、環境保護の適用を目的としていますので、すべてのお客様に安心していただけます。

To fulfil the worldwide standard, JFI has a prefect process with neat packing materials. We ensure that all clients would receive our products & materials in good ordering. Aims are well protection, comprehensive in transportation, easy to find out the components from the shipment and environment saving etc.



4つのポイント

エレベーターはモダンな生活のための新しいソリューションです

生活は驚きに満ちており、JFIはお客様を更なる驚きへと導きます。当社は世界最小のエレベーターを擁しています。いまご自宅にピットレスエレベーターを設置するだけで、お客様が望まれる全機能付エレベーターを設置できます。

Life is full of surprises and JFI brings more to you. JFI has the smallest elevator in the world, PIT less elevator for existing building & full range of elevators fitting your requirements.



Comparison of Energy Usage

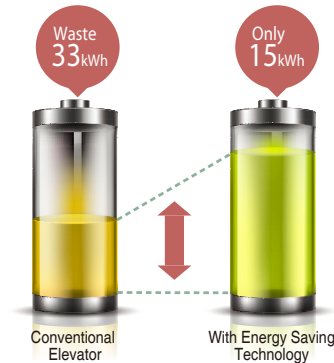

〈 省エネ 〉

約 **50%削減**
(saving energy up to 50%)

省エネ & 低コスト Low Energy Consumption, Save Cost

省エネタイプの高性能な小容量モーターを採用。電気代を抑え、維持費を低コスト化でき、月々の負担も少なくてすみます。入居者にも建物オーナー様にもうれしいエレベーターです。

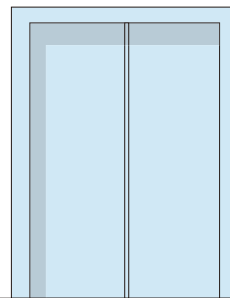

安全設計

Safety Priority, design for your family

さらに一步先を進んだ環境保護のために、JFIは省エネシステムと高効率なエレベーターを提供します。エレベーターは毎日の移動にかかわる交通システムです。お客様の安全と安全な新技術を提供することに関心を寄せています。例えば停電時の自動着床装置、戸階走行保護装置、地震感知器などになります。

Further to save environment, JFI provides energy saving system with higher efficient elevators. Elevators are transportation tool moving every day. JFI cares your safety and providing all of the new technologies for safety to you, such as UPS, UCMP, Seismic device.

Products

New Cabin Style

Product Model

FHS002

仕様 Specification

Car Wall	<ul style="list-style-type: none"> ■ Front Pattern Steel ■ Left Pattern Steel ■ Right Pattern Steel ■ Rear Pattern Steel + Mirror Etching Stainless Steel ■ Handrail Mirror Stainless Steel + Wood Grain
Lighting	<ul style="list-style-type: none"> ■ LED
Ceiling	<ul style="list-style-type: none"> ■ Pattern Steel
Landing Door	<ul style="list-style-type: none"> ■ Pattern Steel
COP	<ul style="list-style-type: none"> ■ FCP022
Floor	<ul style="list-style-type: none"> ■ PVC



Point 1 | エッチングミラー正面壁
Mirror Etched Rear Plate



Point 2 | 空気入れ替えファン
Air Vent with Fan

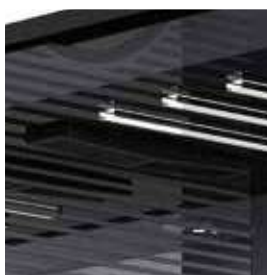

乗場デザイン Landing Door

HOP / COP



FHP014



FCP022



New Cabin Style

Product
Model

FHS004

仕様 Specification

Car Wall	■ Front	Hairline Stainless Steel
	■ Left	Pattern Steel + Mirror Black Stainless Steel
	■ Right	Pattern Steel + Mirror Black Stainless Steel
	■ Rear	Pattern Steel + Mirror Black Stainless Steel
	■ Handrail	Mirror + Wood Grain
Lighting	■ LED	
Ceiling	■ Pattern Steel + Mirror Black Stainless Steel	
Landing Door	■ Pattern Steel	
COP	■ FCP010	
Floor	■ PVC	



Point 1 シーリングライト
Ceiling Light



Point 2 空気入れ替えファン
Air Vent with Fan



乗場デザイン Landing Door

HOP / COP



FHP017



FHP018



FCP010





New Cabin Style

Product Model

FHS006

仕様 Specification

Car Wall	<ul style="list-style-type: none"> ■ Front Hairline Stainless Steel ■ Left Mirror Stainless Steel + Pattern Steel ■ Right Mirror Stainless Steel + Pattern Steel ■ Back Mirror Stainless Steel + Gold Stripe Etching Stainless Steel ■ Handrail Mirror Stainless Steel + Wood Grain
Lighting	<ul style="list-style-type: none"> ■ LED
Ceiling	<ul style="list-style-type: none"> ■ Pattern Steel
Landing Door	<ul style="list-style-type: none"> ■ Pattern Steel
COP	<ul style="list-style-type: none"> ■ FCP013
Floor	<ul style="list-style-type: none"> ■ PVC



Point 1 | ゴールデンストライプステンレス | Gold Striped Stainless Steel



Point 2 | 扇風機の空気を通す口 | Air Vent with Fan



乗場デザイン Landing Door

HOP / COP



FHP016



FCP013



Aluminum Structure

Product
Model

HAL TYPE

仕様 Specification

Ceiling	■ Mirror Stainless Steel + Pattern Steel
Car Wall	■ Mirror Stainless Steel + Pattern Steel + Glass
Floor	■ PVC Anti-Sliding Floor Tiles

※ Material above can be customized

製品の特徴 Features

- No need for concrete shaft structure.
Saving owner's cost.
- Easy and quick installation for new and old houses.
- Minimum inconvenience to home life.
- Little space required.
- Easily carrying while moving.
- Different from common steel plate, the decent coating of aluminum alloy can easily match the interior design.
- By replacing the exterior aluminum plates with glass, the elevator can be converted into observation type which looks more luxurious.

施工事例 Reference Project





Pitless Elevator

FHS014

Product Model

G9 PITLESS ELEVATOR

I-TOUCH System



Fan Control



Elevator Settings



Light Control



仕様 Specification

Car Wall	<ul style="list-style-type: none"> Rose Gold Plated Vibration Stainless Steel Mirror Stainless Steel + Glass
Handrail	<ul style="list-style-type: none"> Leather
Lighting	<ul style="list-style-type: none"> LED
COP	<ul style="list-style-type: none"> FCP016
Floor	<ul style="list-style-type: none"> PVC Anti-sliding Floor Tiles

ピットレスエレベーター

13

PITLESS ELEVATOR

Point 1 革製手すり
Leather Handrail



Point 2 間接照明
Floor Decorating Lights



Point 3 空気入れ替えファン
Air Vent with Fan



乗場デザイン Landing Door

HOP



Transparent Colorless Glass



Transparent Darkened Glass



Non-Transparent Painted Glass



FHP017



FHP018

シャフトデザイン(HAL) Aluminum Shaft Design

RD146

木目調(ライトウッド)
Light Wood Grain
(Transfer Printed)

R116

木目調(ダークウッド)
Dark Wood Grain
(Transfer Printed)

780-4909FITM

ダークブラック
Dark Ink
(Painted)

780-49001IM

シャンパンゴールド
Champagne Gold
(Painted)

A Perfect Solution For 2F-5F Home Lifts.



FHS015



FHS016



仕様 Specification

Car Wall	■ Pattern Steel + Mirror Stainless
Handrail	■ Stainless Steel
Lighting	■ LED
COP	■ FCP018
Floor	■ PVC Anti-sliding Floor Tiles

Point 1 手すり仕様 Handrail Type



Point 2 シーリングライトと間接照明 Ceiling with Direct Lighting



乗場デザイン Landing Door



Dark Wood Grain Panel with Strip Windows



Dark Wood Grain Panel with Grid Windows

Products

Machine Roomless

Product Model

FPS001

仕様 Specification

Ceiling	■ Fashionable Type
Lightings	■ Energy Saving LED
Car Operating Panel	■ FCP019
Hall Operating Panel	■ FHP016
Handrail	■ Hairline Stainless Steel
Cabin Wall	■ Pattern Steel
Landing Door	■ Pattern Steel
Cabin Door	■ Pattern Steel
Flooring	■ PVC Tiles



Point 1 | 機械室なし
Machine Room Less Elevator



Point 2 | 簡単お手入れ
Easy to Clean Surface



乗場デザイン Landing Door

HOP / COP



FHP016



FCP019

Machine Roomless

Product
Model

FPS002

仕様 Specification

Ceiling	■ Stylish Type
Lightings	■ Energy Saving LED
Car Operating Panel	■ FCP017
Hall Operating Panel	■ FHP016
Handrail	■ Hairline Stainless Steel
Cabin Wall	■ Pattern Steel
Landing Door	■ Pattern Steel
Cabin Door	■ Pattern Steel
Flooring	■ PVC Tiles

Point 3 PMギアレスモーター

Gearless Motor



Point 4

エネルギー効率A級

Class A Energy Efficiency

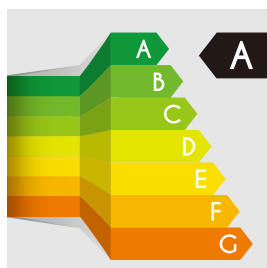

乗場デザイン Landing Door

HOP / COP



FHP016



FCP017



Products

Panoramic Lift

One-Piece Perfect Circular
Transparent Elevator

Product
Model

FOB007

一体型の透明円形エレベーター

17

OBH



仕様 Specification

Ceiling	■ Star-Type
Car Wall	■ Mirror Titanium with Glass
Floor	■ Marble Floor Tiles
COP	■ FCP004-2 (Full Length)



Point 1 | 360度の視野角
360 Round Glass View

Luxurious Integrated-Designed



一体型の透明円形エレベーター



18

OBH

Point 2 | 螺旋階段に合わせた設計
Fits Well with Circular-Staircase

Point 3 | 両側に操作盤を配置
Dual Car Operating Panel

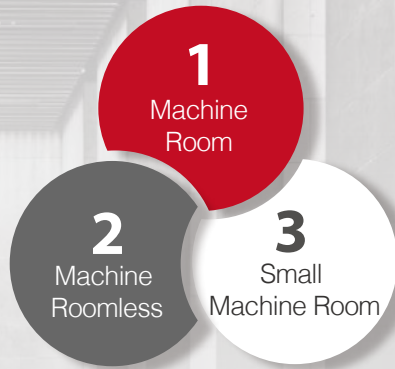

With **Machine Roomless Technology**, all equipments are installed inside hois tway. No space needed for machine room, which won't rest rain the design of building.

- Cost s aving on machine room.
 - Short construction time.
 - Limit on OH height is sol ved.
 - Replace lift of hydraulic type.
 - Noiseless and no vibration.
 - Energy S aving Design.
 - Feature with Earthquake Sensor (Seismic Sensor).
- Location of traction machine varies from design and customer's request.



VVVF Door Operator System



Product Model

PAINTED



仕様 Specification

Ceiling	■ Painted Steel
Car Wall	■ Painted Steel
Floor	■ PVC Anti-Sliding Floor
COP	■ FCP021

Cabin Wall

PATTERN STEEL MATERIAL



LNA-14



LC-14



LW-6920



LNA-15



LNA-24



LNW-1



LG-01



LW-9284



LNA-18



LG-04



LNW-24



LC-108

Cabin Enclosure

STEEL

Product Model

PATTERN STEEL

Product Model

HAIRLINE STAINLESS STEEL

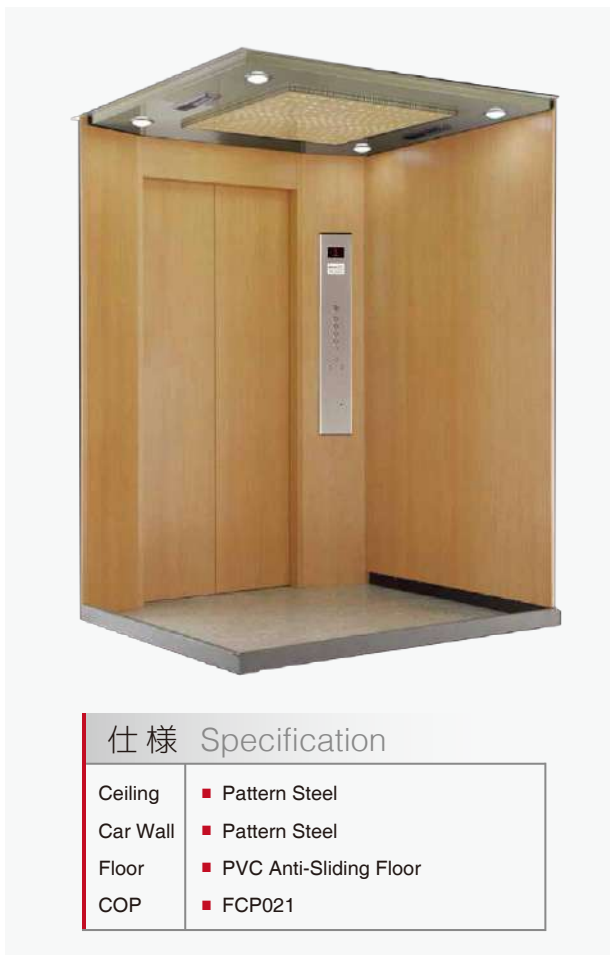

仕様 Specification

- Ceiling ■ Pattern Steel
- Car Wall ■ Pattern Steel
- Floor ■ PVC Anti-Sliding Floor
- COP ■ FCP021

仕様 Specification

- Ceiling ■ Hairline Stainless Steel
- Car Wall ■ Hairline Stainless Steel
- Floor ■ PVC Anti-Sliding Floor
- COP ■ FCP021

Floor Material

PVC Tile



X-7223

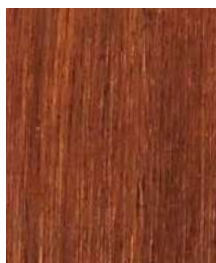

X-7210



X-7211



X-859



X-853



X-860



X-7223



X-860+X-859

Products

For Factory and Hospital

Product Model

CARGO LIFT

仕様 Specification

Ceiling	■ Hairline Stainless Steel
Car Wall	■ Hairline Stainless Steel
Floor	■ Checkered Stainless Steel Plate
COP	■ FCP008



Disable HOP / COP



FCP008



FHP008

Product Model

BED LIFT

仕様 Specification

Ceiling	■ FCL502 FCL503 FCL504 (Standard) FCL501 (Optional)
Car Wall	■ Pattern Steel
Floor	■ PVC Anti-Sliding Floor Tiles
COP	■ FCP001



天井仕様 Ceiling



FCL502 (Standard)

FCL503 (Standard)



FCL504 (Standard)

FCL501 (Optional)

For Commercial Public Facilities

Product
Model

ESCALATOR & MOVING WALK

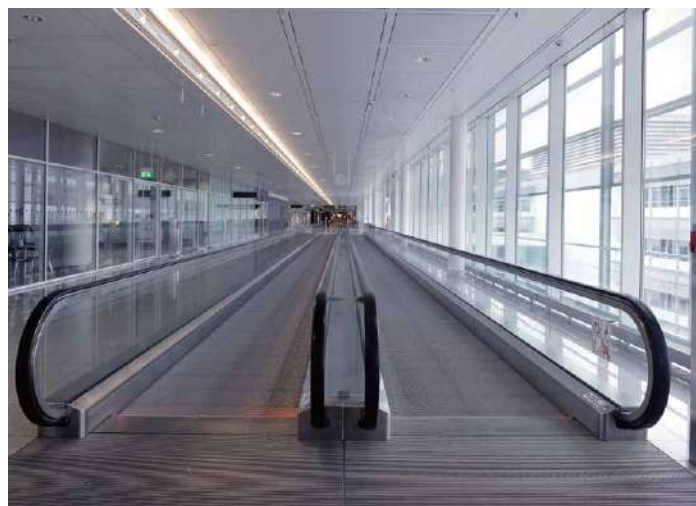

JFI escalators set industrial standards for safety, eco-efficiency, and visual design. Our flexible solutions not only serve both indoor and outdoor environments, including small to large commercial buildings, stations, airports, etc. but also save space for entrance and exit areas. With experienced and skilled designing group, we're able to provide quality, safe escalators to all users.

JFI moving walks perfectly show high standards of technology. In airports and malls, besides transporting huge passenger flows, moving walks also deliver shopping carts, wheelchairs, baby carts, and luggage. With features of safety and reliability, JFI moving walks are able to offer high performance with silent operation to all users.

レイアウト Layout

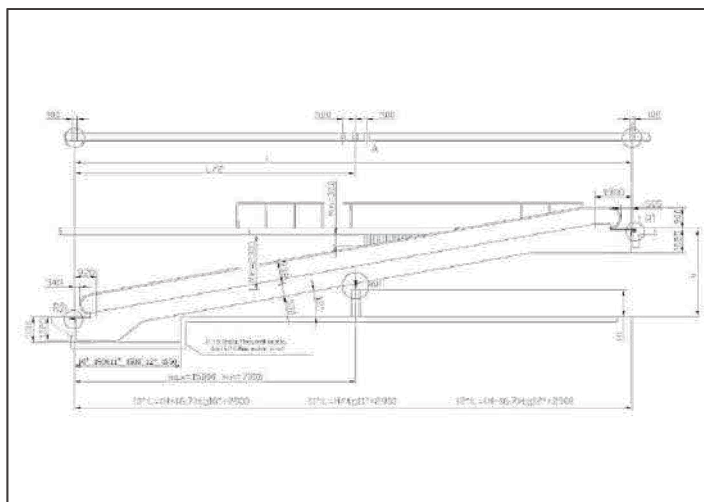
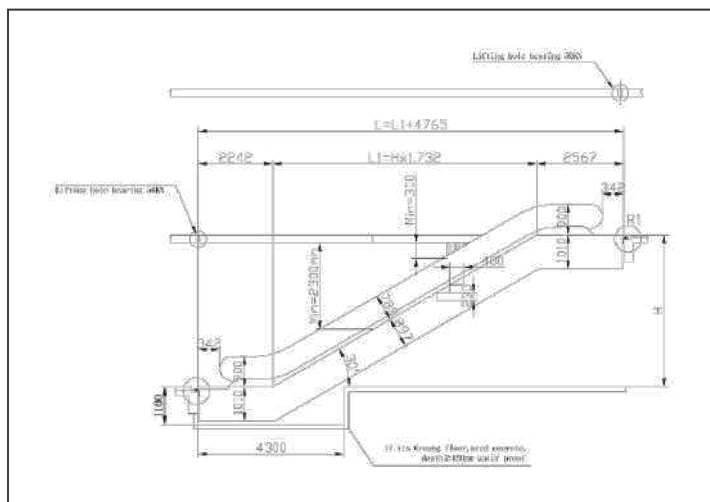

Cabin
Design

Ceiling Style

Parts

CEILING

スタンダード Standard



FCL101
Chinese Style Steel Sheet
Coating



FCL102
Star-Type Steel Sheet
Coating



FCL103
Steel Sheet Coating of
Shooting Star Type



FCL104
Steel Sheet Coating of
Round-Spot

オプション Optional



FCL201
Green Forest Type



FCL202
Red Maple Type



FCL203
Snowy Type



FCL204
Starry Night Type



FCL205
Blue Sky Type



FCL301
Cross Type Arc Shape Sheet



FCL302
Stripe Type Arc Shape Sheet



FCL303
Grid Type Arc Shape Sheet

Handrail Type

Parts

HANDRAIL

ステンレス製 Stainless Steel



FHR001

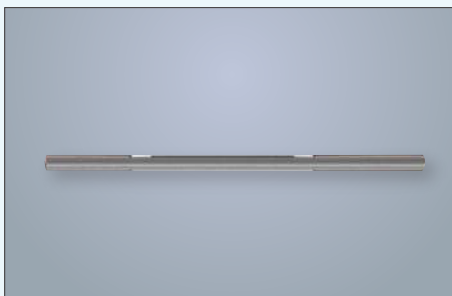

FHR002



FHR003

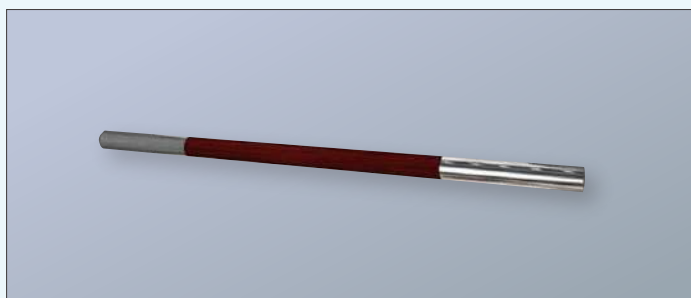

FHR004

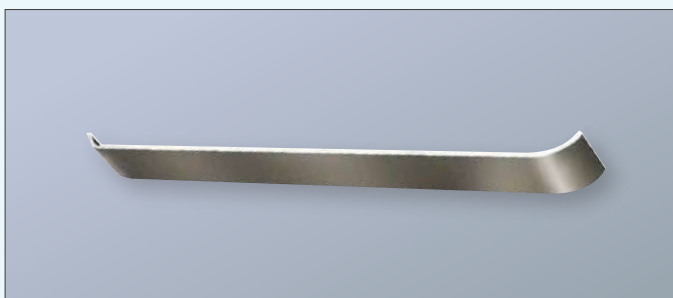

FHR005

革製 Leather

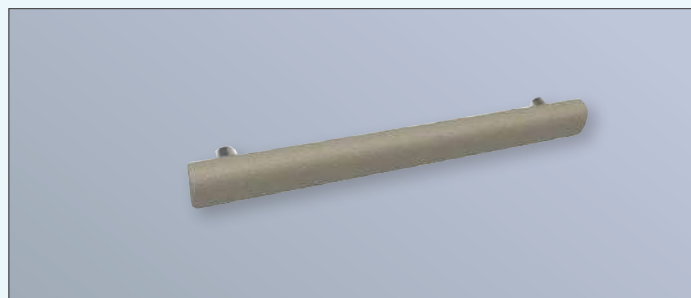

FHR006

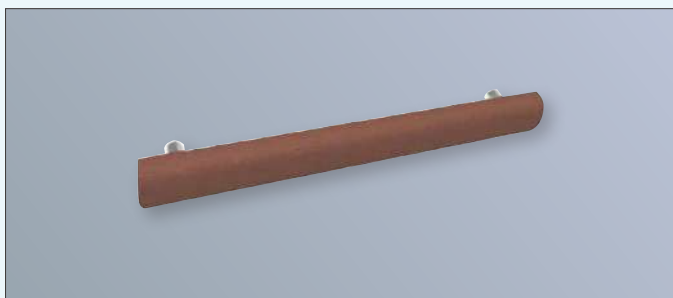

FHR007

Cabin Design

Operating Panel



FCP022

FCP021



FHP004



FHP006



FHP015



FHP021



FCP005



FCP012-02



FCP013

Cabin Design

Landing Door



Part STANDARD



FLD001



FLD002



FLD003



FLD004

Part GLASS

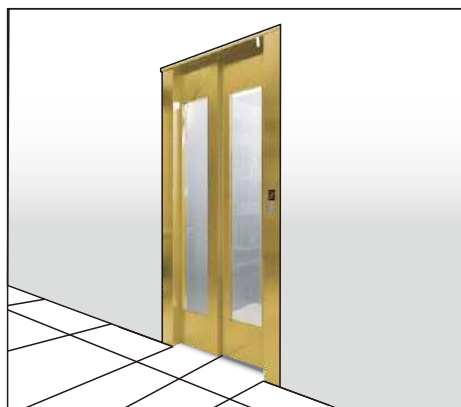

FLD005

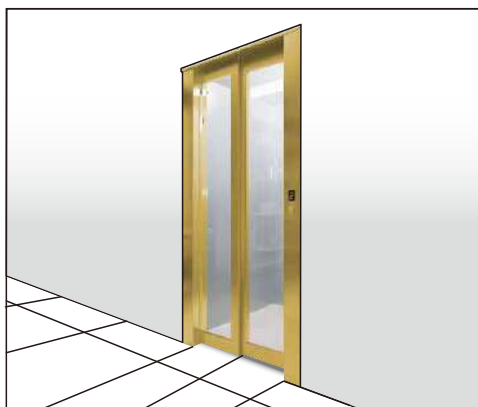

FLD006

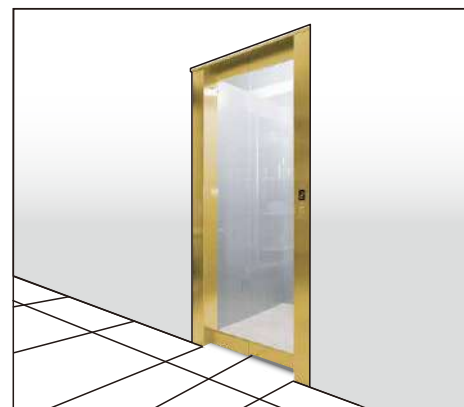

FLD007

Part DOOR JAMB

Home Lift



FDJ002
Standard
Narrow Frame



FDJ004
Wide and
Straight Frame



FDJ006
Maintenance
Door Frame

Passenger Lift

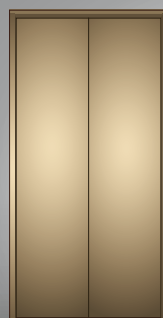

FDJ001
Standard
Narrow Frame

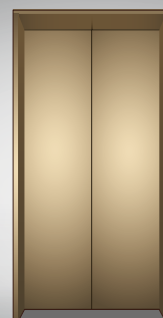

FDJ003
Slanted
Wide Frame

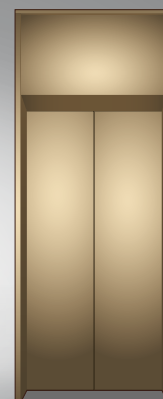

FDJ005
Slanted and
Wide Frame

Function

Features Introduction

主な機能一覧表 Features

スタンダード Standard

オプション Optional

タッチスクリーン操作
Touch Panel

I-TOUCH



色彩調整可能な照明
Lighting Adjustment

ADJUSTABLE



大きな空間
Extended Cabin Size

READY FOR DISABLED OR WHEELCHAIR



Notes : Wheelchair size could be variety, please check to your local vendor.



はさまれ防止センサー
Safety Door Sensor



LEDライト

Full LED Lighting

FULL LED



エネルギー効率

Certified Energy Efficiency

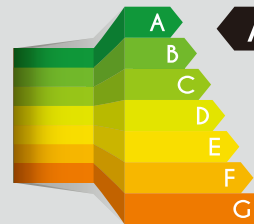

CLASS A



使いやすいデザイン

User-Friendly Patent Design

BIG BUTTON



スムーズで快適

Smooth and Comfort

SPEED



Meter/Minutes

5TH FLOOR

17.5
METER

Approx. 19 sec

UPS (無停電電源装置)

UPS Uninterruptible
Power System



ARD
AUTO
RESCUE
DEVICE

SMSスマートメンテナンスシステム

Smart Maintenance System

ELEVATOR MONITORING

Real-time Elevator Monitoring, Instant Reporting on Various Malfunctions.



機能紹介

27

FUNCTION



Application for the Building

製品表 Product Application

P.XX ← 対応製品の概要は、ページを参照ください。
For the summary of the corresponding product, please go to page Number.

建築タイプ
Types of buildings

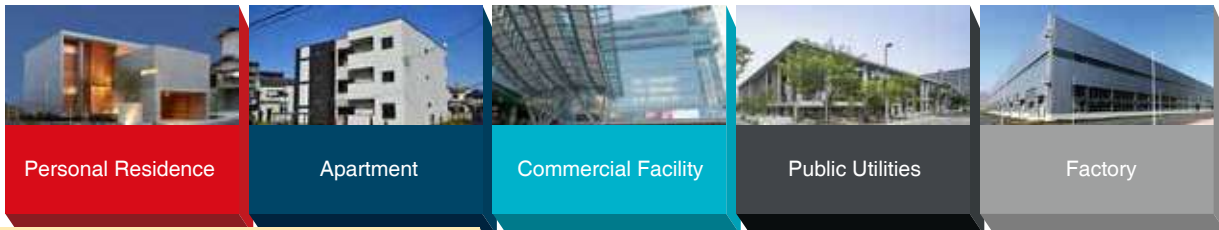

Standard Type	For Home	<p>FHS002 P.09 ← HAL P.12 ←</p> <p>FHS004 P.10 ← G9 PITELESS P.13 ←</p> <p>FHS006 P.11 ← FPS001 P.15 ←</p>			
	Building		<p>FHS002 P.09 ← FPS001 P.15 ←</p> <p>FHS004 P.10 ← FOB007 P.17 ←</p> <p>FHS006 P.11 ←</p>		
	For Goods				<p>CARGO LIFT P.21 ←</p>
Customized Type	Commercial Building		<p>FHS002 P.09 ← FPS001 P.15 ←</p> <p>FHS004 P.10 ← FOB007 P.17 ←</p> <p>FHS006 P.11 ←</p>		
	Factory Use			<p>CARGO LIFT P.21 ←</p>	<p>CARGO LIFT P.21 ←</p>
	Hospital Use				<p>BED LIFT P.21 ←</p>

Safety

Safety Features



Safety Detector

TWO IN ONE SAFETY EDGE

オプション Optional

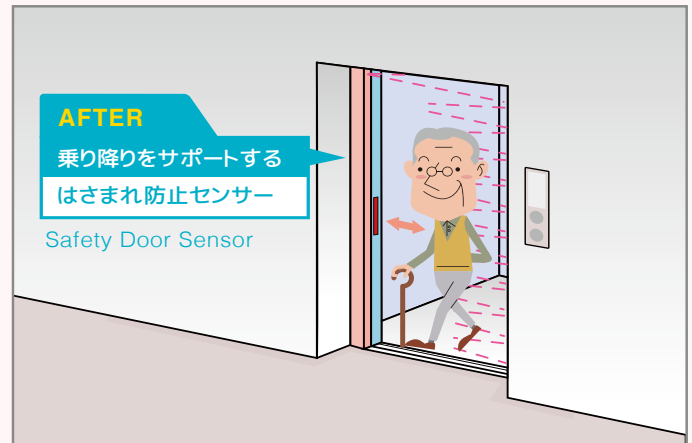

エレベーターのドア上下1.8m間に40本の赤外線が発光。1本でも赤外線を遮ると、ドアの先端に設けられた安全装置（セーフティシュー）が手や身体を使って押さえなくてもドアが反転するシステムです。

Double protection with mechanical safety edge plus infrared light curtain.(2 in 1)

Safety Detector

UCMP (Unintended Car Movement Protection)

オプション Optional



▼ Elevator Moving Down



▲ Elevator Moving Upward

新安全基準に対応した、戸開走行保護装置を採用。ドアが開いたままエレベーターが昇降しないよう、自動的にエレベーターを制止します。UCMP回路と二重系ブレーキとの連携で、故障時にも安全を守ります。

When UCMP detects abnormal car movement more than 7.5 cm, it will instantly activate the brake to stop the car.

Safety Features



Safety Detector FLOOD DETECTOR オプション Optional

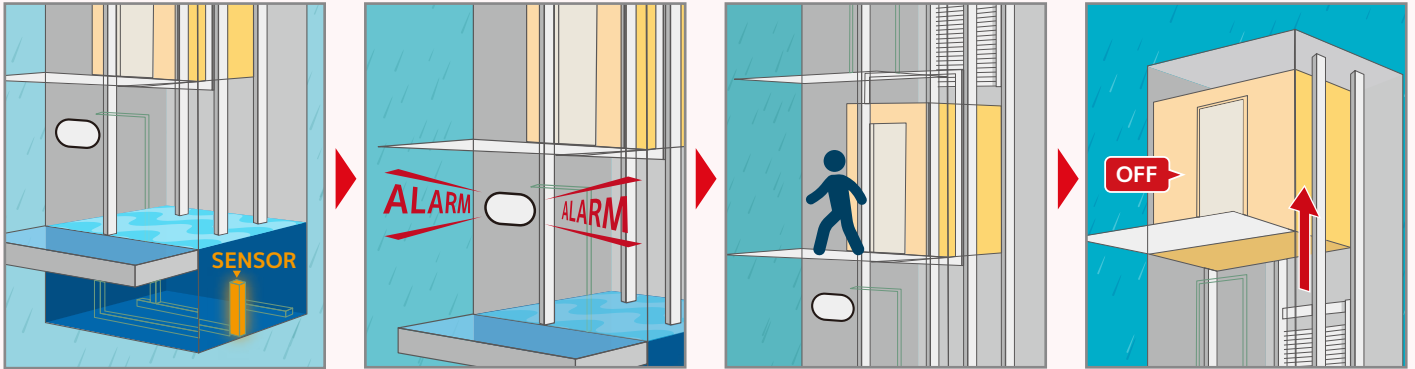

- 1 Sensor sends signals to broadcaster while detecting flood in the pit.
- 2 Broadcaster sounds the alarm and sends signals to controller.
- 3 Controller drives the car to safe floors.
- 4 Car moves second top floor and opens the door, then shut off for safety concern.

ピット内で冠水を検知すると、エレベーターが運転を休止します。
 ＊冠水検知時にエレベーターが最下階に停止している場合は、退避階まで運転した後休止します。
 When flood detector detects water inside the pit, it'll move the elevator to the 2nd highest floor.

Safety Detector EARTHQUAKE SENSOR オプション Optional

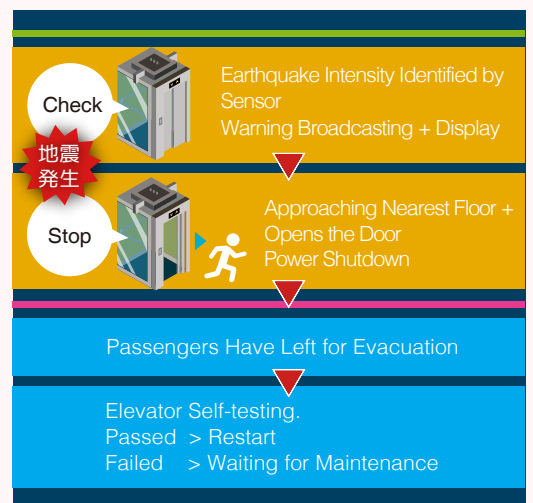
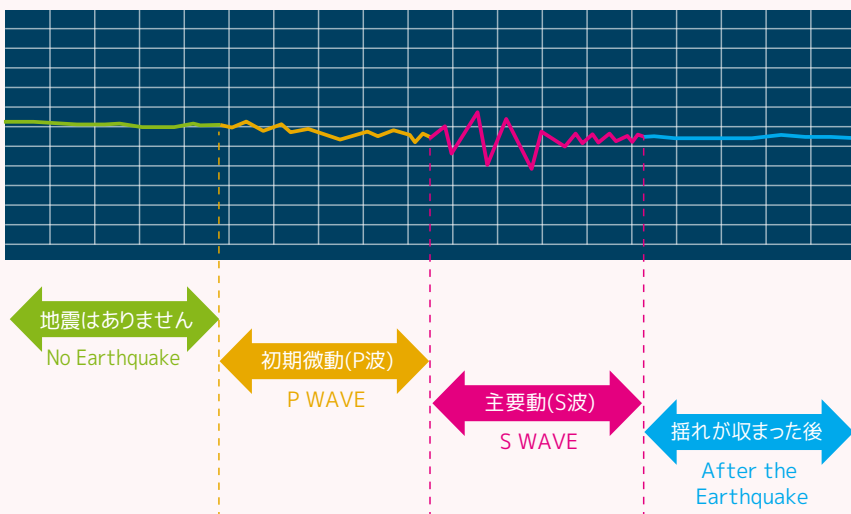

地震で休止したエレベーターを自動で診断。異常がなければ運転を再開させ、地震時のエレベーター休止時間を短く抑えます。
 When earthquake sensor detects P waves & S waves, the elevator will be directed to the nearest floor for evacuation.

Function

Standard Function

Feature	Description
1. Automatic Levelling	Auto levelling and re-levelling, ensuring level between car and landing door sill.
2. Emergency Car Lighting	Emergency in car lighting during power failure of the main building power supply.
3. Door Safety Detector	A self test feature that monitor door safeties upon switching from inspection to automatic mode.
4. False Call Cancelling	Cancelling registered call at the Car Operating Panel (COP) by double tapping registered floor button.
5. Energy Conservation	Lift inverter goes into sleep mode together with light and fan within the car will be switched off automatically after a pre-determined period of time, after answering the last call.
6. Main Floor Parking	Lift will return to main floor (pre-determined) after last registered call.
7. Door Hold	Extending door opening time by pressing "Door Open" and "Call Button" on the Car and Hall Operating Panel respectively.
8. Door Nudging Feature	If an obstacle prevents the door from closing, the door will repeatedly open and close until the object is removed.
9. Overload Weighing Device	Overload safety device that render the lift to be inoperative and an activated alarm.
10. Anti-Nuisance	Registered calls will be cancelled in the event that the load is lesser than expected within the lift car.
11. Car Reverse Direction	Reverse direction calls will be cancelled upon completion of the last registered call of the same direction.
12. Re-Leveling Function	Auto re-leveling in a low speed when a car stops between floors due to malfunction.
13. Car Door Safety Edge	Mechanical safety device in additon to lift curtain sensor.
14. Emergency Intercom System	Emergency communication device with someone outside the lift.

Optional Function

Feature	Description
1. Automatic Fault Logging	Provide comprehensive fault data on recent breakdowns (up to 20 fault tracking).
2. Manual Operation	Switching the automatic lift car operation to manual mode.
3. Automatic Rescue Device (ARD)	An emergency power to bring the lift to nearest adjacent landing during building power failure.
4. Seismic Detector	Returning of lift car to the nearest landing for evacuation upon the detection of earthquake.
5. Card / Bio-Matrix	Advance lift access control by means of fingerprint or access card system.
6. Global System for Mobile Communication (GSM)	Automatic GSM notification system in the event of breakdown or main building power failure.
7. Remote Monitoring Function	Real time elevator monitoring system via 3G network.
8. Supervisory Panel	On site monitoring of lift (s) operation status.
9. Security Code Call	Enabling person with password to access specific floors.
10. Voice Synthesizer	Lift car announcement system.
11. Parking Mode	Lift goes into energy conservation mode by means of a key switch to disable all Hall Call Panels.
12. Non-Service Floor	Lift will not serve this pre-determined floor.
13. Priority Floor	Priority will be given and the elevator will serve this floor first before other registered call (s).
14. VIP Priority Service	VIP calling service at specific floor by means of access control system.
15. Door Infra-Red Sensor	Multi-beam safety curtain sensor fitted on the lift car door.
16. Infrared Curtain	Optical sensor detecting obstacles along the doorway and prevent elevator door from closing.
17. 2 In 1 Safety Door Edge	An enhanced door safety feature that combines both infra-red and mechanical safety edge.
18. Extended Door Hold	Extend door opening time for greater convenience with additional button on Car Operating Panel.
19. Car Arrival Chime	Lift car arrival chime upon arrival of desired floor.
20. Hall Arrival Chime	Audible chime upon the arrival of lift at the particular floor.
21. Hall Arrival Lantern	Arrival lantern installed at lobby will lit up upon arrival of lift.
22. Fire Return Service	Return of lift to designated level for evacuation in the event that the fire alarm is activated.
23. Fireman Operation	Elevator return to designated floor with door remained open for fireman operation.
24. Group Control System	Capable of controlling up to 8 elevators that manage traffic flow efficiently hence reducing waiting time during peak hours.
25. Selective Collective Automatic Operation	Answering of relevant landing call (s) in the direction of travel.
26. Automatic Floor Support	Assigning of alternate car to serve call that is not answered by the primarily assigned car in time.
27. Overall Independent Lift Standby Function	Elevator cars distributed to standby at different floors that effectively reduces waiting time.
28. Peak Service	Designated floor will be given priority during peak hours.

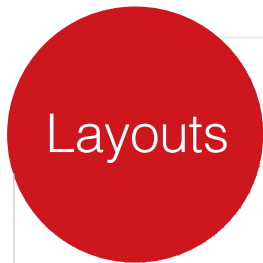

Passenger Lift Construction Information

エレベーター平面図（機械室なし）

Construction Drawing (Machine Roomless)

エレベーター平面図（機械室あり）

Construction Drawing (Machine Room)

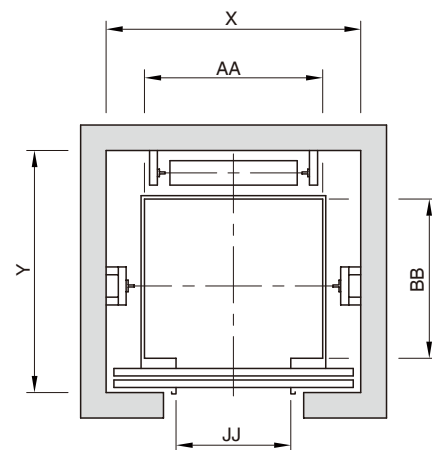
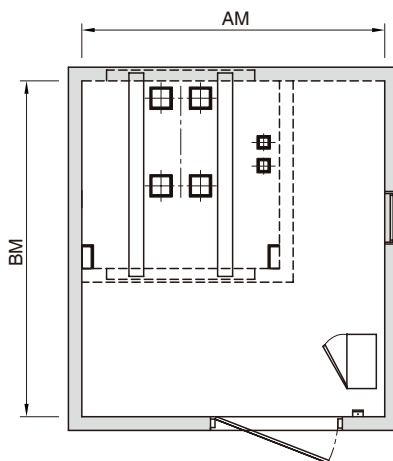
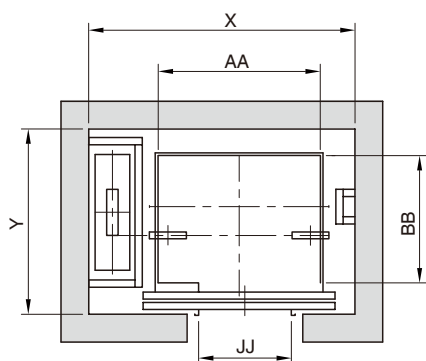
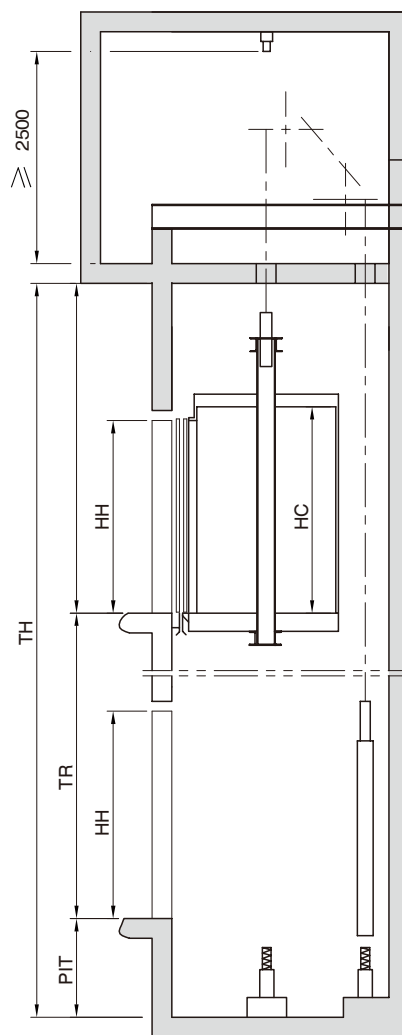
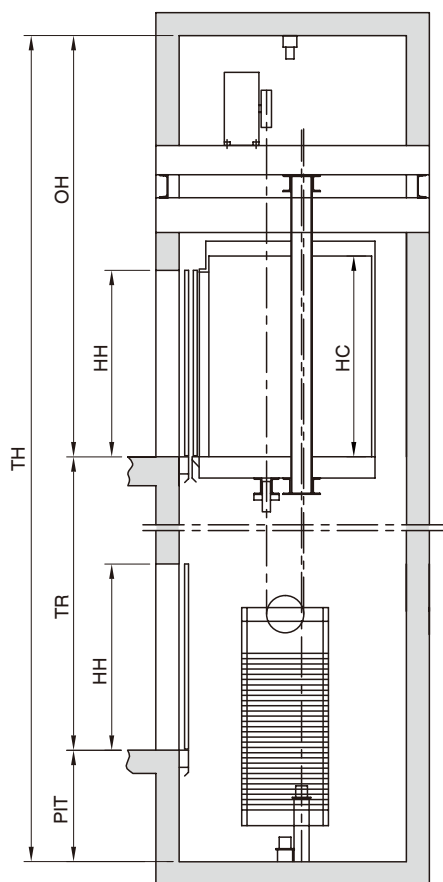

Passenger Lift Construction Information

エレベーター寸法表 Specifications

TYPE	CAPACITY	SPEED	DOOR OPEN	ENTRANCE DIMENSION		CAR INTERIOR DIMENSION			HOISTWAY		MACHINE ROOM	
	(KGS)	m/min	TYPE	JJ	HH	AA	BB	HC	X	Y	AM	BM
P	450	45-60	CO	800	2100	1400	850	2300	1750	1450	2000	2900
	550	45-105	CO	800	2100	1400	1030	2300	1750	1590	2000	3100
	600	45-105	CO	800	2100	1400	1100	2300	1750	1660	2000	3200
	700	45-105	CO	800	2100	1400	1250	2300	1750	1810	2000	3400
	750	45-105	CO	800	2100	1400	1350	2300	1750	1910	2000	3500
	820	45-105	CO	800	2100	1400	1400	2300	1750	1960	2000	3600
	900	45-105	CO	900	2100	1600	1350	2300	2100	1930	2500	3500
	1000	45-105	CO	900	2100	1600	1500	2300	2100	2080	2500	3700
	1150	45-105	CO	1100	2100	2000	1350	2300	2500	2100	2900	3800
	1350	45-105	CO	1100	2100	2000	1500	2300	2500	2250	2900	4100
1600	45-105	CO	1100	2100	2000	1750	2300	2500	2500	2900	4500	
EML-P	450	45-60	CO	800	2100	1400	850	2300	1800	1500		
	550	45-105	CO	800	2100	1400	1030	2300	1800	1700		
	600	45-105	CO	800	2100	1400	1100	2300	1800	1750		
	700	45-105	CO	800	2100	1400	1250	2300	1800	1950		
	750	45-105	CO	800	2100	1400	1350	2300	1800	2050		
	820	45-105	CO	800	2100	1400	1400	2300	1800	2100		
	900	45-105	CO	900	2100	1600	1350	2300	2100	2100		
	1000	45-105	CO	900	2100	1600	1500	2300	2100	2250		
	1150	45-105	CO	1100	2100	2000	1350	2300	2600	2200		
	1350	45-105	CO	1100	2100	2000	1500	2300	2600	2350		
1600	45-105	CO	1100	2100	2000	1750	2300	2600	2600			
EMS-P	450	45-60	CO	800	2100	1400	850	2300	1750	1450	1750	1450
	550	45-105	CO	800	2100	1400	1030	2300	1750	1590	1750	1590
	600	45-105	CO	800	2100	1400	1100	2300	1750	1660	1750	1660
	700	45-105	CO	800	2100	1400	1250	2300	1750	1810	1750	1810
	750	45-105	CO	800	2100	1400	1350	2300	1750	1910	1750	1910
	820	45-105	CO	800	2100	1400	1400	2300	1750	1960	1750	1960
	900	45-105	CO	900	2100	1600	1350	2300	2100	1930	2100	1930
	1000	45-105	CO	900	2100	1600	1500	2300	2100	2080	2100	2080
	1150	45-105	CO	1100	2100	2000	1350	2300	2500	2100	2500	2100
	1350	45-105	CO	1100	2100	2000	1500	2300	2500	2250	2500	2250
1600	45-105	CO	1100	2100	2000	1750	2300	2500	2500	2500	2500	

TYPE	SPEED	45m/min	60m/min	90m/min	105m/min	120m/min	150m/min
	ITEM						
P	OH(mm)	4500(4000)	4500(4000)	4700(4200)	4700(4500)	5000(4700)	5200(4900)
	PIT(mm)	1500(1200)	1500(1200)	1850(1700)	1850(1700)	2100(2000)	2100(2000)
EML-P	OH(mm)	4100(3700)	4100(3700)	4300(4000)	4500(4200)	4800(4500)	5000(4700)
	PIT(mm)	1500(1200)	1500(1200)	1850(1700)	1850(1700)	2100(2000)	2100(2000)
EMS-P	OH(mm)	5700(5000)	5700(5200)	6000(5400)	6000(5600)	6300(5800)	6300(6000)
	PIT(mm)	1500(1200)	1500(1200)	1850(1700)	1850(1700)	2100(2000)	2100(2000)

Construction Information

OBH平面図 OBH Construction Drawing

仕様 Specification

Load	■ 450KG
Speed	■ 30m/m
Door Open	■ CO
Car Internal Size	■ $\varnothing 1240$, HC=2300
Entrance Width	■ JJ=700, HH=2100
Rope	■ 2:1 ($\varnothing 10 \times 3V$)
Car Rail	■ 13K
Cwt Rail	■ 8K

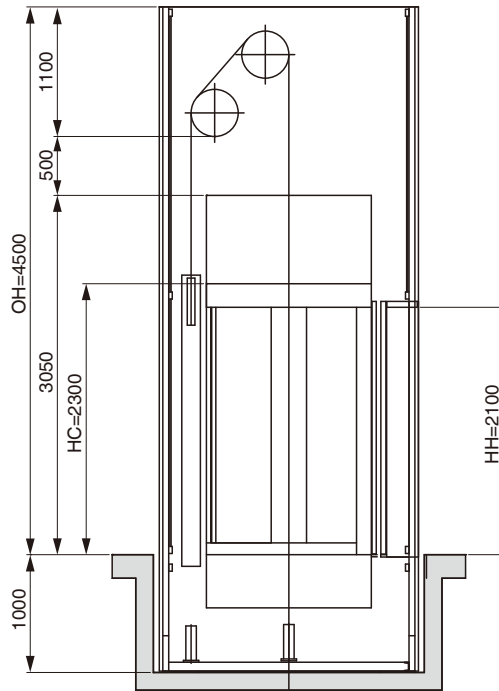

ELEVATOR SECTION

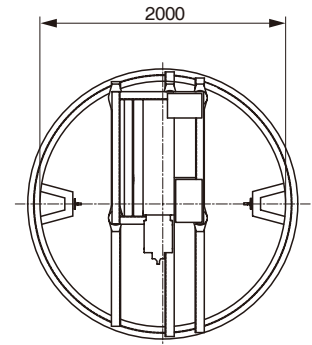

MACHINE ROOM PLAN

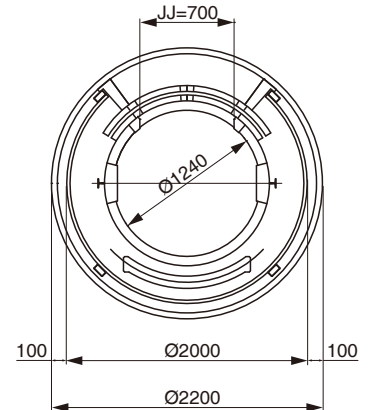

SHAFT PLAN

G9平面図 G9 Construction Drawing

仕様 Specification

Type	■ HAL-G9
Load	■ 320KG
Speed	■ 20m/m
Max Travel	■ 15m
Max Stops	■ 5 Floors
Door Open	■ 2CO
Machine Room	■ Machine Room Less
Car Dimension	■ 900*1050*2200
Entrance	■ 750*2000
Aluminum Shaft	■ 1300*1400
OH	■ 2850
Pit	■ 150

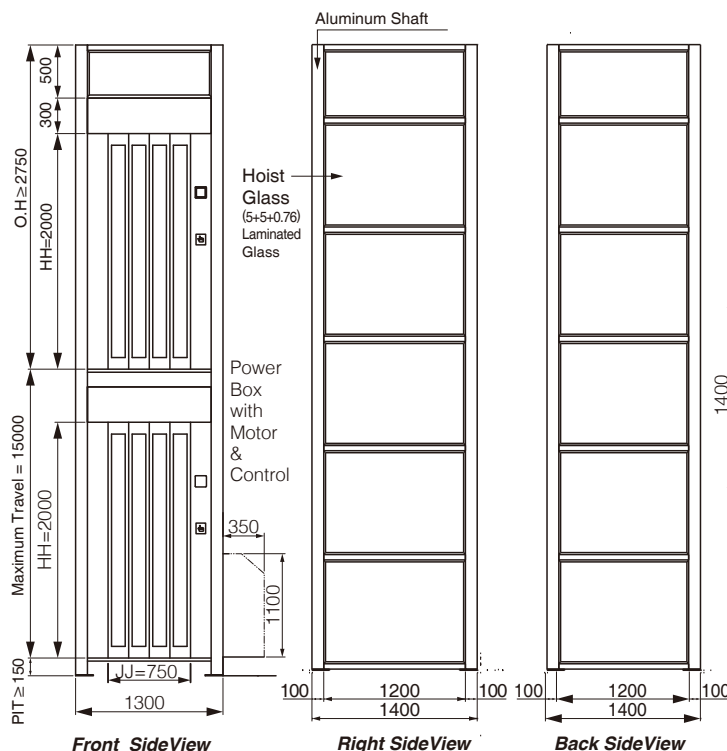

Front SideView

Right SideView

Back SideView

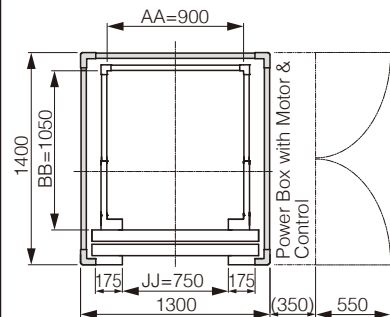

Home Lift Construction Information

ホームエレベーター平面図 Home Lift Construction Drawing

■ Single Entrance (Steel structure, RC structure)

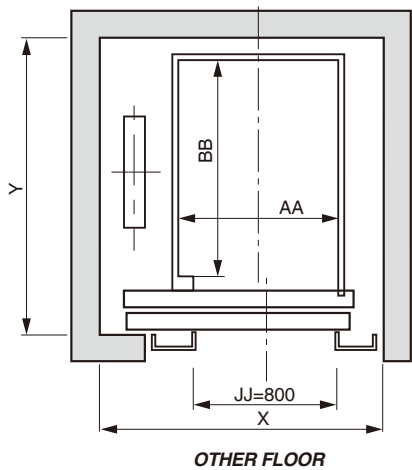

■ Double Entrance (Steel structure, RC structure)

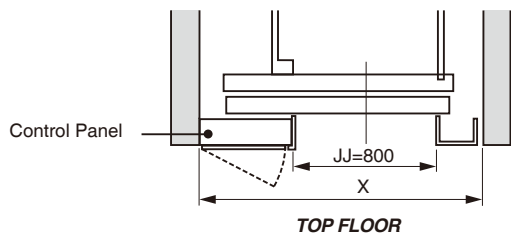
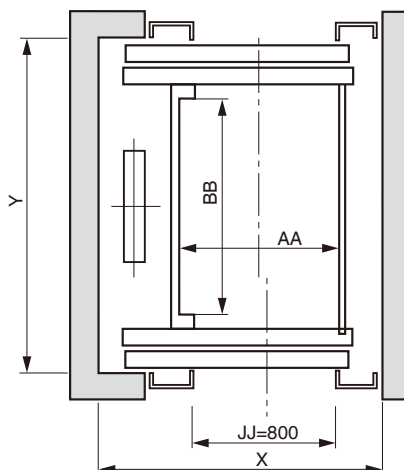

HRC	Single Entrance (XxY)	Double Entrance (XxY)	(AAxBBxHC)
140 KG	1550x1250	1550x1450	900Wx900Dx2100H
200 KG	1550x1550	1550x1750	900Wx1200Dx2100H
320 KG	1550x1550	1550x1750	
400 KG	1600x1550	1600x1750	
450 KG	1600x1550	1600x1750	

ホームエレベーター仕様 Specifications

Purpose	Resident Use				
Machine Room	Machine Roomless				
Driving Type	Wire Rope				
Rated Load	2 persons (140kg)	3 persons (220kg)	4 persons (320kg)	5 persons (440kg)	6 persons (450kg)
Power	Motor	Single Phase 220V, Triple Phase 220V/380V			
	Light/Fan	110V/220V, 50Hz/60Hz			
Motor	1.5kw	1.5kw	2.2(3.0)kw	2.2(3.7)kw	3.7kw
Maximum Stop	6 stops				
Maximum Travel(R)	20 meters				
Rated Speed	20m/min		30(45)m/min		
Door Opening	2 panels side opening				
Cabin Size(mm) AAxBBxCC	900x900x2100	900x1200x2100			
Entrance Size(mm)	800x2000				
OH	3200	3200	3400		
Pit	500	700	1000		
Remark	-	For Self-Operated Wheelchair			

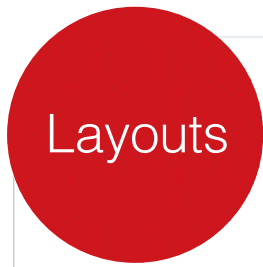

GPX Type Construction Information



GPX平面図 GPX Construction Drawing

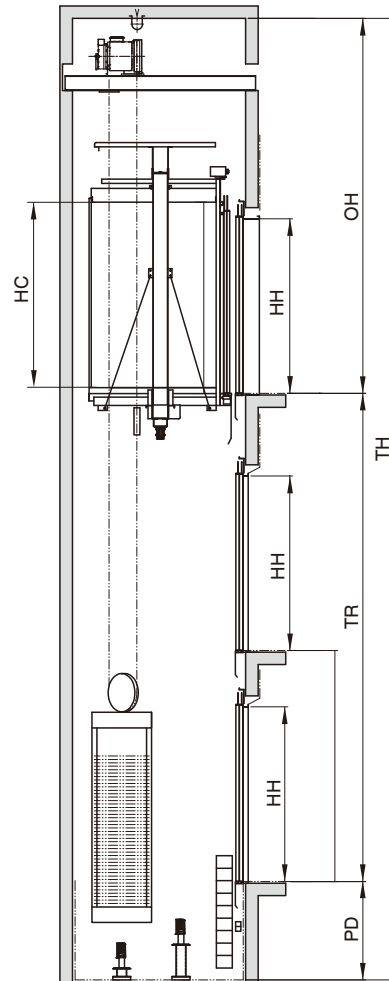
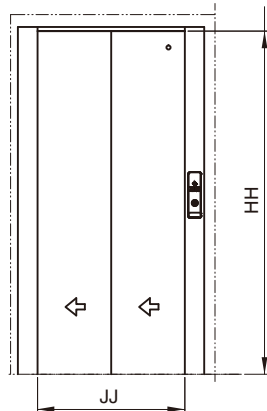
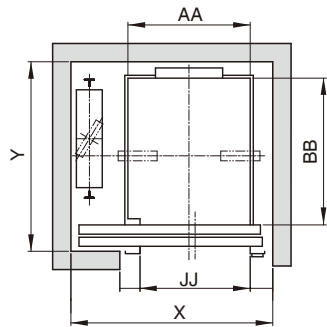

GPX規格 GPX Specifications

TYPE	CAPACITY	SPEED	DOOR OPEN	ENTRANCE DIMENSION		CAR INTERIOR DIMENSION			HOISTWAY	
	(KGS)	m/min	TYPE	JJ	HH	AA	BB	HC	X	Y
A	450	45	2S	900	2100	1000	1200	2200	1650	1550
	550	60	2S	900	2100	1000	1400	2200	1650	1750
	630	60	2S	900	2100	1100	1400	2200	1750	1750
B	450	45	2S	900	2100	1000	1200	2200	1650	1550
	550	60	2S	900	2100	1000	1400	2200	1650	1750
	630	60	2S	900	2100	1100	1400	2200	1750	1750

Bed Lift Type Construction Information

寝台用エレベーター平面図 Bed Lift Construction Drawing

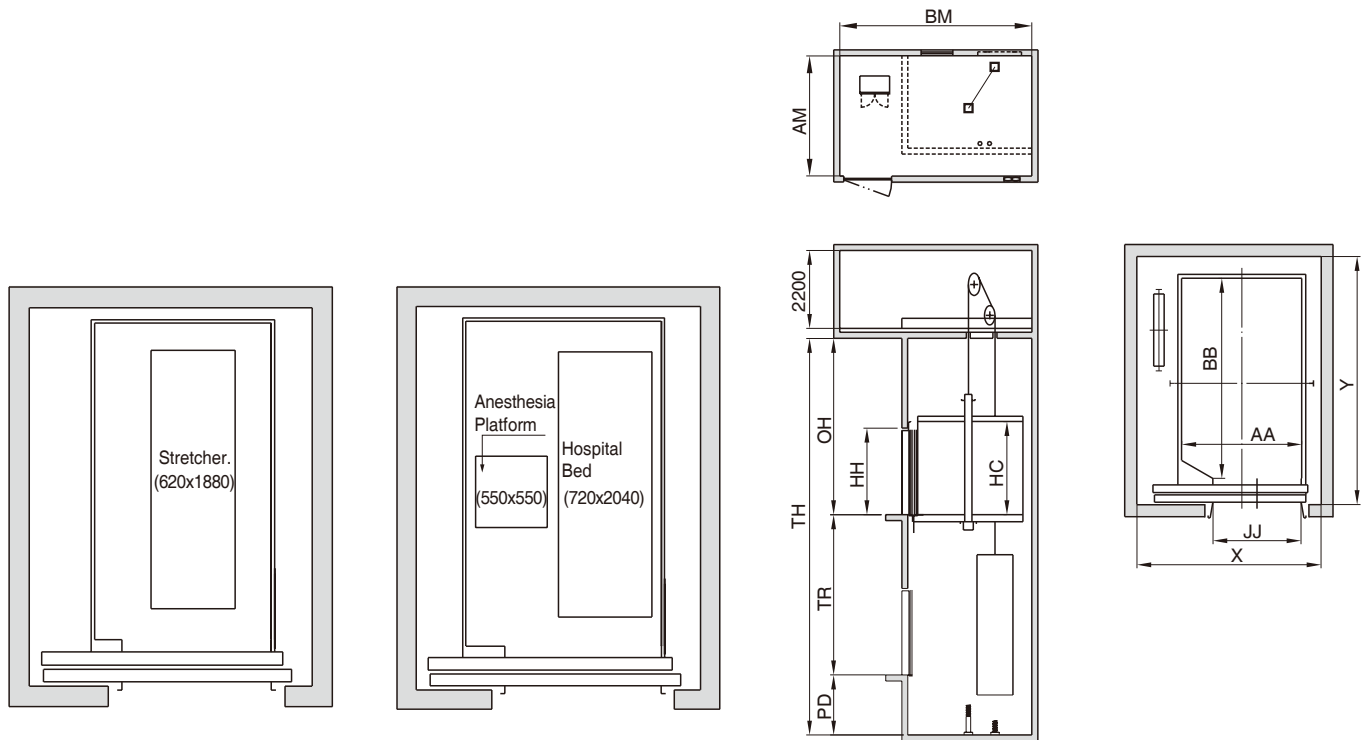

基本仕様および平面図・取付図

寝台用エレベーター規格 Bed Lift Specifications

TYPE	CAPACITY	SPEED	DOOR OPEN	ENTRANCE DIMENSION		CAR INTERIOR DIMENSION			HOISTWAY		MACHINE ROOM	
	(KGS)	m/min	TYPE	JJ	HH	AA	BB	HC	X	Y	AM	BM
B	750	45-90	2S	1100	2100	1300	2300	2300	2050	2900	2600	4600
	1000	45-90	2S	1100	2100	1500	2500	2300	2300	3100	3000	4800
EML-B	750	45-90	2S	1100	2100	1300	2300	2300	2150	2900		
	1000	45-90	2S	1100	2100	1500	2500	2300	2400	3100		
EMS-B	750	45-90	2S	1100	2100	1300	2300	2300	2050	2900	2050	2900
	1000	45-90	2S	1100	2100	1500	2500	2300	2300	3100	2300	3100

TYPE	ITEM	SPEED	45m/min	60m/min	90m/min	105m/min
B	OH(mm)		4200(4200)	4400(4200)	4600(4300)	4800(4500)
	PIT(mm)		1250(1350)	1550(1500)	1850(1800)	2150(1950)
EML-B	OH(mm)		3900(4200)	4100(4200)	4300(4300)	4500(4500)
	PIT(mm)		1250(1550)	1550(1550)	1800(1800)	2100(2100)
EMS-B	OH(mm)		5700(5500)	5900(5600)	6100(5700)	6300(5800)
	PIT(mm)		1250(1550)	1550(1550)	1850(1850)	2150(2100)

革新から満足へ

Innovation to Satisfaction.



JAPAN FUJI
INTERNATIONAL



Japan Fuji International Co., Ltd

〒270-0144 千葉県流山市前ヶ崎599-3

599-3, Maegasaki, Nagareyama Shi, Chiba Ken, 270-0144, Japan

TEL : +81-3-45780389 E-mail : info@fujilift.co.jp

www.fujilift.co.jp

DM141A02